



Alfa Laval CPM

Regulating valves

Introduction

The Alfa Laval CPM Constant-Pressure Modulating Valve is a pneumatic regulating valve that maintains a constant pressure in hygienic process lines at the valve inlet or outlet. Safe, reliable and easy to clean, these regulating valves provide accurate pressure control, quickly adjusting position to maintain the pressure at pre-set values without any need for electronic control.

Application

This pneumatic regulating valve maintains uniform inlet or outlet pressure in hygienic process lines for the dairy, food, beverage, personal care and many other industries. Typical applications include filling and bottling equipment.

Benefits

- Safe, effective pressure control
- Self-draining design
- Excellent valve cleanability
- Easy to install, simple to operate
- High hygienic level

Standard design

The CPM Constant-Pressure Modulating Valve is available in three versions: the CPMI-2, the CPMO-2, and the CPM-I-D60. The CPMI-2 and the CPMO-2 consist of a valve body with valve seat, cover, valve plug with a special diaphragm, and clamp. The diaphragm consists of two flexible PTFE and EPDM diaphragms supported by 12 stainless steel sectors between them. The cover and the valve body are clamped together. The valve body and the seat are welded together. The CPM-I-D60 consists of a valve body in two parts, an upper body and a lower body, as well as an inlet tube, cover, valve plug with diaphragm unit, and clamps. The cover and valve bodies are clamped together. ATEX version is also available.

Working principle

The Alfa Laval CPM Constant-Pressure Modulating Valve is controlled from a remote location by means of compressed air. A diaphragm or valve plug system reacts immediately to any alteration of product pressure and adjusts its position accordingly to maintain a constant inlet and outlet pressure at pre-set values.



TECHNICAL DATA

Pressure	
Max. product pressure:	1000 kPa (10 bar)
Min. product pressure:	0 kPa (0 bar)
Air pressure (CPMI-2/CPMO-2):	0 to 800 kPa (0 to 8 bar)
Air pressure (CPM-I-D60):	0 to 600 kPa (0 to 6 bar)

Temperature	
Temperature range:	-10°C to 95°C (EPDM)
Temperature range with upper diaphragm in PTFE/EPDM:	-10° C to +140° C (Higher on request)

Flow	
Flow Kv 23, fully open ($\Delta p = 1$ bar):	Approx 23 m ³ /h
Flow Kv 7 ($\Delta p = 1$ bar):	Approx 7 m ³ /h
Flow Kv 9 ($\Delta p = 1$ bar):	Approx 9 m ³ /h
Flow Kv2/15, low capacity ($\Delta p = 1$ bar):	Approx 2 m ³ /h
(Alternative size)	(regulating area). Approx. 15 m ³ /h. (CIP area)
Flow range Kv60, fully open ($\Delta p = 1$ bar) (CPM-I-D60)	Approx 60 m ³ /h

PHYSICAL DATA

Materials	
Product wetted steel parts:	1.4404 (316L)
Other steel parts:	1.4301 (304)
Lower diaphragm:	PTFE covered EPDM rubber
Upper diaphragm	NBR

Surface finish choose from the following:	
Standard	
Internal/external semi-bright:	Ra \leq 1.6 μ m
Optional	
Inside/outside	Ra \leq 0.8 μ m or 0.5 μ m

Air Connections	
R 1/4" (BSP), internal thread	

Options

- A. Male parts or clamp liners in accordance with required standard.
- B. Air pressure regulating valve kit, 0-8 bar.
- C. Air throttling valve for adjustment of regulating speed for the CPM-2 valve.
- D. Booster for product pressure exceeding the available air pressure. (Product pressure = 1.8 x air pressure).
- E. US 3A version available on request for CPM-2 valves only

Material grades CPM-2

- F. Upper diaphragm of PTFE covered EPDM and O-ring of FPM covered EPDM, (for temperature 95-140°C).
- G. Both diaphragms of solid PTFE and O-ring of FPM (for temperatures above 140°C).

Material grades CPM-I-D60

- H. Upper diaphragm of PTFE covered EPDM.
- I. Valve body seal rings of NBR or FPM.
- J. Guide O-ring of FPM (for temperatures above 95°C).

Fig. 1. Principle

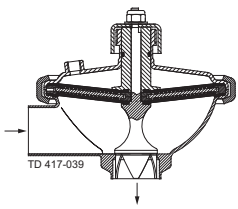

CPMI-2
a. Reduced product pressure.

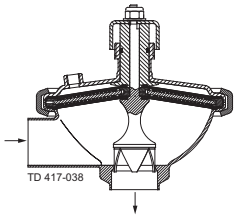

CPMI-2
b. Increased product pressure.

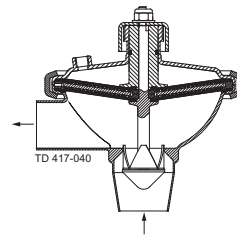

CPMO-2

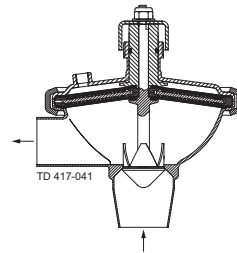

CPMO-2

CPMI-2 and CPMI-D60 opens at increasing product pressure and vice versa.
CPMO-2 closes at increasing product pressure and vice versa.

Diaphragm Unit

CPMI-2 and CPMO-2: The diaphragm unit consists of a stainless steel disc which is divided into sectors and of flexible diaphragms which are placed on each side of the sectors. CPMI-D60: The diaphragm unit consists of two flexible diaphragms supported by 12 stainless steel sectors in between them.

Note!

For further details, see also instructions ESE01825 and ESE01834

Fig. 2. CPMI-2 with pressure regulating valve and pressure gauge

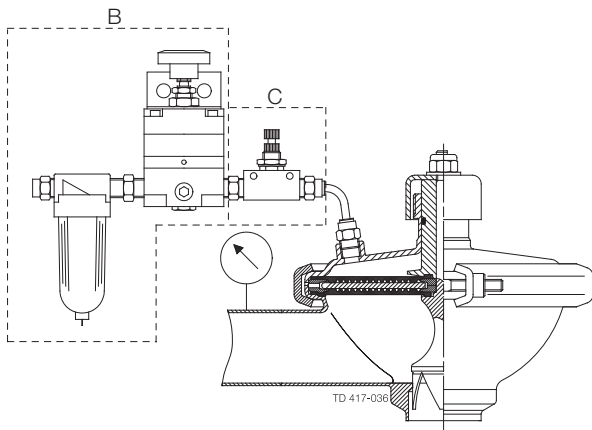

The valves operate without a transmitter in the product line and require only a pressure regulating valve for the compressed air and a pressure gauge in the product line.

Pressure drop/capacity diagrams

CPM-2, Kv 23

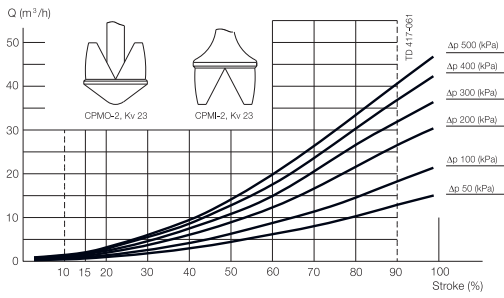

CPMI-2, Kv 7

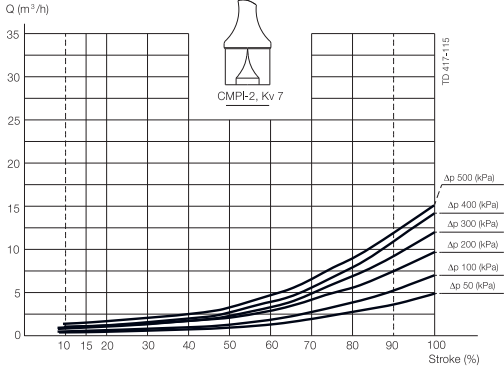

CPM-2, Kv 2/15

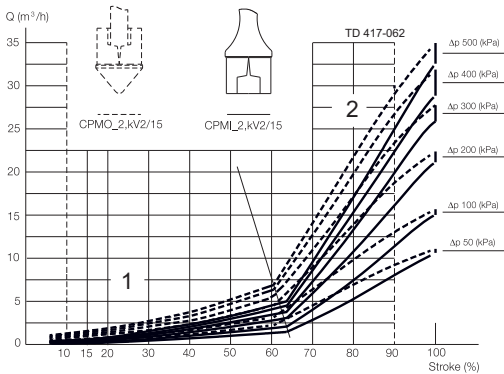

Example 1:

Pressure drop $\Delta p = 200$ kPa.

Flow $Q = 8$ m³/h.

Select: CPM-2, Kv 23 which at working point will be 48% open.

Example 2:

CPMI-2:

Pressure drop $\Delta p = 300$ kPa.

Flow $Q = 1$ m³/h.

Select: CPMI-2, Kv 2/15 which at working point will be approx. 35% open equal to about 50% of the regulating area.

Note!

For all diagrams the following applies:

Medium: Water (20°C).

Measurement: In accordance with VDI 2173.

Alfa Laval recommend max. flow velocity in tubing and valves to be 5 m/sec.

CPMO-2, Kv 9

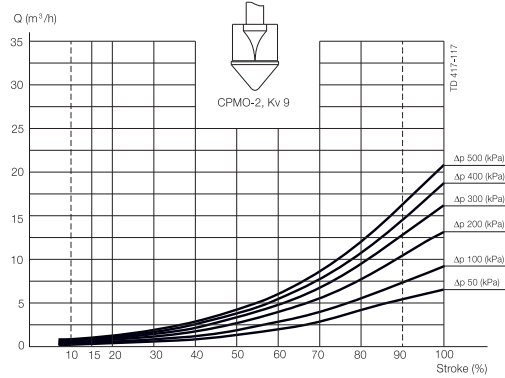

CPM-I-D, Kv 60

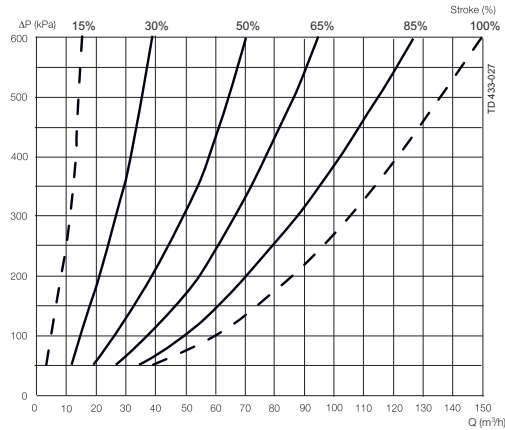

Example of using the diagram:

1. Pressure drop $\Delta p = 300$ kPa.

2. Flow = 50m³/h.

The intersection is on the 50% curve.

Note!

Always try to get as close as possible to the 50% open curve. If the CPM-I-D60 is too big select from the CPMI-2 curves.

Alfa Laval reserves the right to change specifications without prior notification.

How to contact Alfa Laval

Contact details for all countries
are continually updated on our website.
Please visit www.alfalaval.com to
access the information direct.